

Original MINI Accessories. Installation Instructions.



Retrofit - Steering stop

MINI One (R56)

MINI Cooper (R56)

MINI Cooper S (R56)

MINI Clubman (R55)

MINI Clubman S (R55)

MINI Convertible (R57)

Retrofit kit no.: 32 10 6 777 974 Retrofit kit, steering stop

Installation time

The installation time is approx. 1.0 hour, but may vary depending on the condition of the car and the equipment in it.

The vehicle must be updated to the latest I-level status by flashing before installing the retrofit. Different programming times are necessary depending on the production age of the vehicle and the work already performed on the vehicle so that no time requirements can be specified here. The installation time does not include the time required for programming/encoding which depends on the vehicle's age and equipment.

Important information

These installation instructions are primarily designed for use within the MINI dealership organisation and by authorised BMW service companies.

In any event, the target group for these installation instructions is specialist personnel trained on MINI cars with the appropriate specialist knowledge.

All work must be completed using the latest BMW repair manuals, circuit diagrams, servicing manuals and work instructions, in a rational order, using the prescribed tools (special tools) and observing current health and safety regulations.

To avoid unnecessary extra work and/or costs, if any installation or function problem occurs, after a brief troubleshooting session (approx. 0.5 hours), please contact the following:

- 1. Either your national subsidiary or your regional office, or**
- 2. The Support team via the Aftersales Assistance Portal (ASAP), using the optional technical parts support application.**

Specify the chassis number and the part number of the installed retrofit kit and give a precise description of the problem.

Do not archive the hard copy of these installation instructions since daily updates are made by ASAP!

All pictures show LHD cars; proceed accordingly on RHD cars.

Pictograms

 Denotes instructions that draw your attention to special features.

◀ Denotes the end of the instruction or other text.

Installation information

The installation instructions describe the procedure on the left-hand side of the vehicle only. The same procedure should be followed analogously on the right-hand side of the vehicle.

Replace gaiters in accordance with TIS repair instructions.

Print out workshop certificate (Section 5, Page 8), complete and hand over to customer.

Hand over attached TÜV Certificate to customer.

Special tools required

32 3 210 Open-ended/box spanner

36 1 250 Wheel hub grinder

36 1 300 Set of wheel bolt adapters

Contents

Section	Page
1. Parts Overview	4
2. Preparatory work	5
3. Installation.....	6
4. Concluding work and coding	7
5. Workshop certificate	8

1. Parts Overview

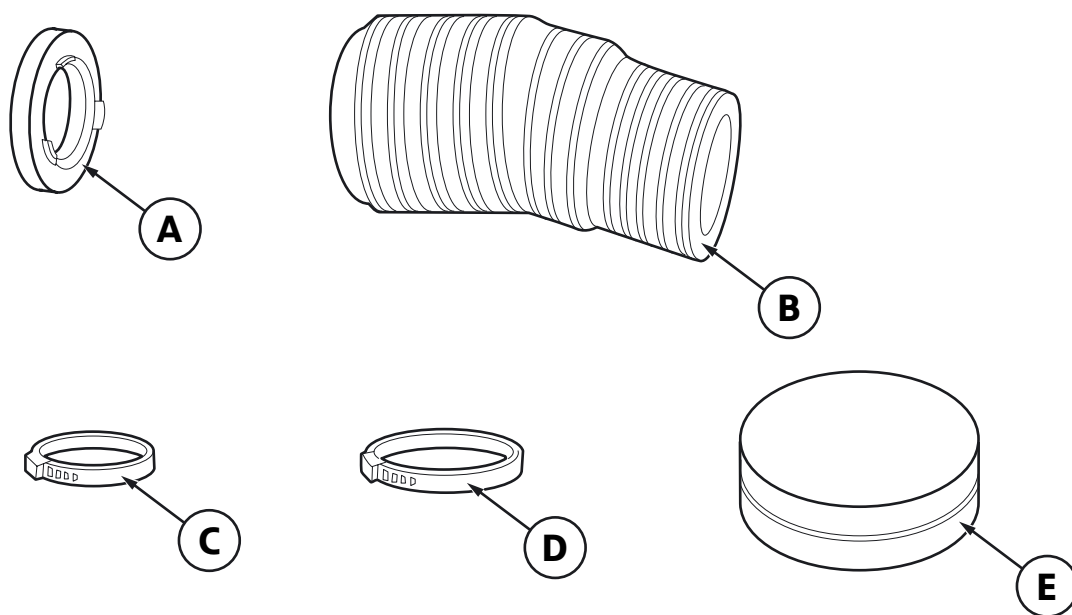

056 0181 V

Legend

- A** Stop ring (2x)
- B** Gaiter (2x)
- C** Hose clip, small (2x)
- D** Hose clip, large (2x)
- E** Assembly grease

2. Preparatory work

	TIS No.
Perform quick test	—
Disconnect negative terminal of battery	12 00 ...
Remove the following components	
Remove front wheels	36 10 300
Left and right track rod (only inner)	32 21 231
 The track rod end need not be removed for the purpose of installing the steering stop. ◀	
Replace gaiter on left and right track rod.	—

3. Installation

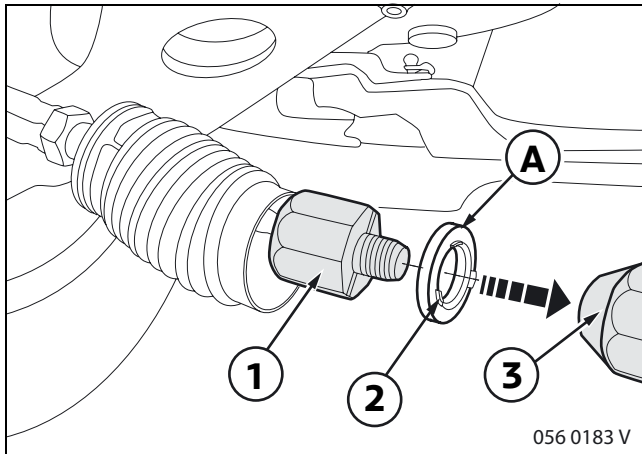

Slide stop ring **A** onto steering linkage (3).

 Deformation element (2) must face towards cone (3). ◀

Install track rod (1) with steering linkage (3) in accordance with TIS No. 32 21 231.

4. Concluding work and coding

The retrofit system does not require encoding.

- Reassemble vehicle in reverse order of removal
- Perform standard wheel alignment check with DIN load in accordance with TIS No. 32 00 150
- Adjust toe-in on front axle in accordance with TIS No. 32 00 601
- Reconnect vehicle battery
- Perform quick test

 Complete workshop certificate (Section 5, Page 8) and hand over to customer.

Hand over attached TÜV Certificate to customer. ◀

5. Workshop certificate

The completed document with signature and company stamp confirms that the steering stop retrofit kit

R56 Part number:	32 10 6 777 974
------------------	-----------------

was installed in full on the vehicle specified in the following.

The main element of the steering stop is the installation of the stop ring between the track rod and the rack and pinion on both sides.

The certificate additionally confirms that the vehicle tracking was checked and readjusted after installation of the steering stop.

Model:	R56
Steering stop, part number:	32 10 6 777 974
Vehicle type:	MINI-N(e1*2001/116*0343*)

Vehicle licence number:

Vehicle identification number:

Vehicle owner: (Name and address)

.....

.....

.....

Place, date

Signature:

Workshop: (company stamp)